

HET EFFECT VAN
DEALCOHOLISATIE:

UNDERSTANDING THE
SENSORY EFFECT OF
DEALCOHOLIZATION

AND STRATEGIES FOR
SUBSTITUTING THE SENSORY
EFFECT OF ALCOHOL

Dr. Matthias Schmitt

MSc. Lorenzo Italiano

INTRODUCTION

Market share of non-alcoholic alternatives continues to grow.

The share of non-alcoholic wine in Germany is still relatively small (1,5% vol.), but production, demand and awareness are steadily increasing.

With sparkling wines we are more advanced:

→ the share of dealcoholized sparkling wine increased in Germany from 6,8 –to 7,5% vol. (VDS)

According to YouGov, 47% of 18-24 year olds in the EU do not drink alcohol.

However, pressure on the industry is growing, including strict anti-alcohol campaigns.

Non-alcoholic continues to grow in many countries

Predicted development of non-alcoholic and low-alcoholic wines 2021-2025 by country

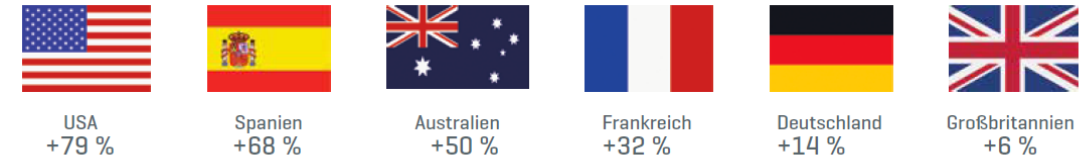

Quelle: IWSR Drinks Market An



Europe's Beating Cancer Plan Makes Alcohol Policy Key Element of Cancer Prevention

Posted on February 3, 2021 in [Obstacle To Development](#), [Policy](#), [Prevention](#), [Recovery](#), [Social Justice](#), [Sustainable Development](#)

INTRODUCTION

Non-alcoholic wine, or dealcoholized wine, is not a 'new' product.

The first patent for producing alcohol-free wine by vacuum distillation was granted in 1903.

Professional production of non-alcoholic wine has been made since 1908 (Carl Jung, Rüdesheim, Germany).

Production is mainly in the hands of specialists, whose numbers are increasing.



NON-ALCOHOLIC

written by
Valerie Kathawala
published
July 10, 2023

SHARE



Germany Is Driving the Quality Revolution for Non-Alcoholic Wine

By focusing on quality base wines and technological advancements, Germany is building on its long history of non-alcoholic wine production

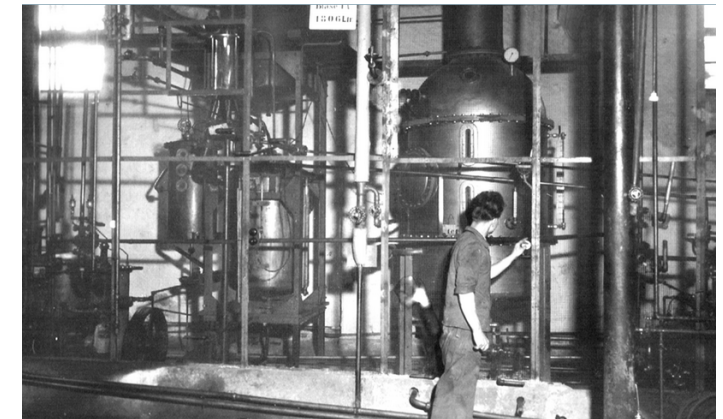

TECHNOLOGY

APPROACHES BASED ON DISTILLATION



APPROACHES BASED ON MEMBRANE TREATMENTS



VACUUM RECTIFICATION

1908 Company Carl Jung/Rüdesheim patent on plant for vacuum distillation

Common for production of dealcoholized wine and beer

Continuous de-alcoholization < 0,5% vol. + blending

Process temperature 30-40°C / 100-120mbar

→ Total loss of CO₂ / **dealcoholized sparkling wine?**

Distillate > 70% vol. → commercialization as sprit / brandy

In Germany due to tax issues under sealed conditions

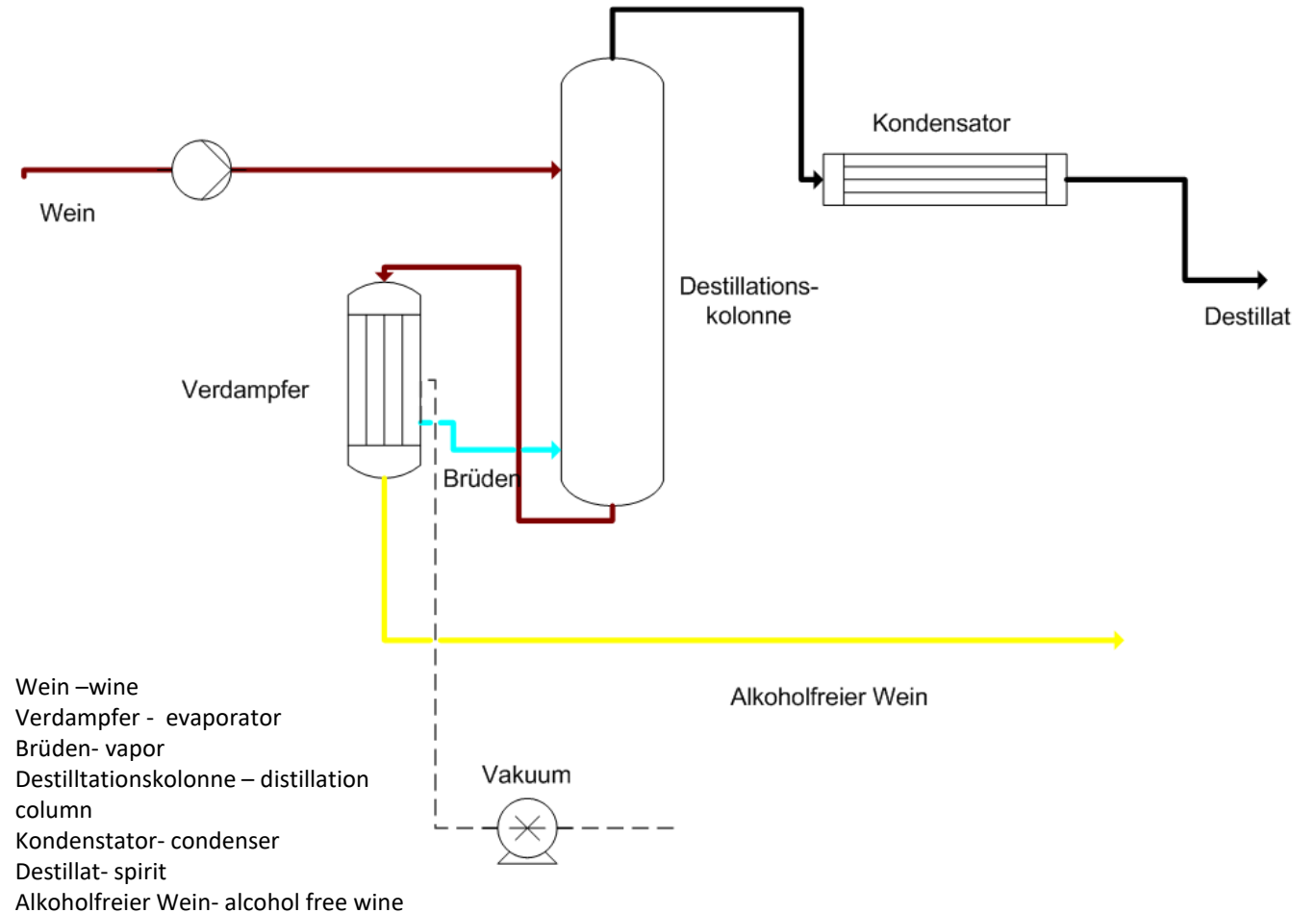

VAKUUM RECTIFICATION IN 2 PASSAGES

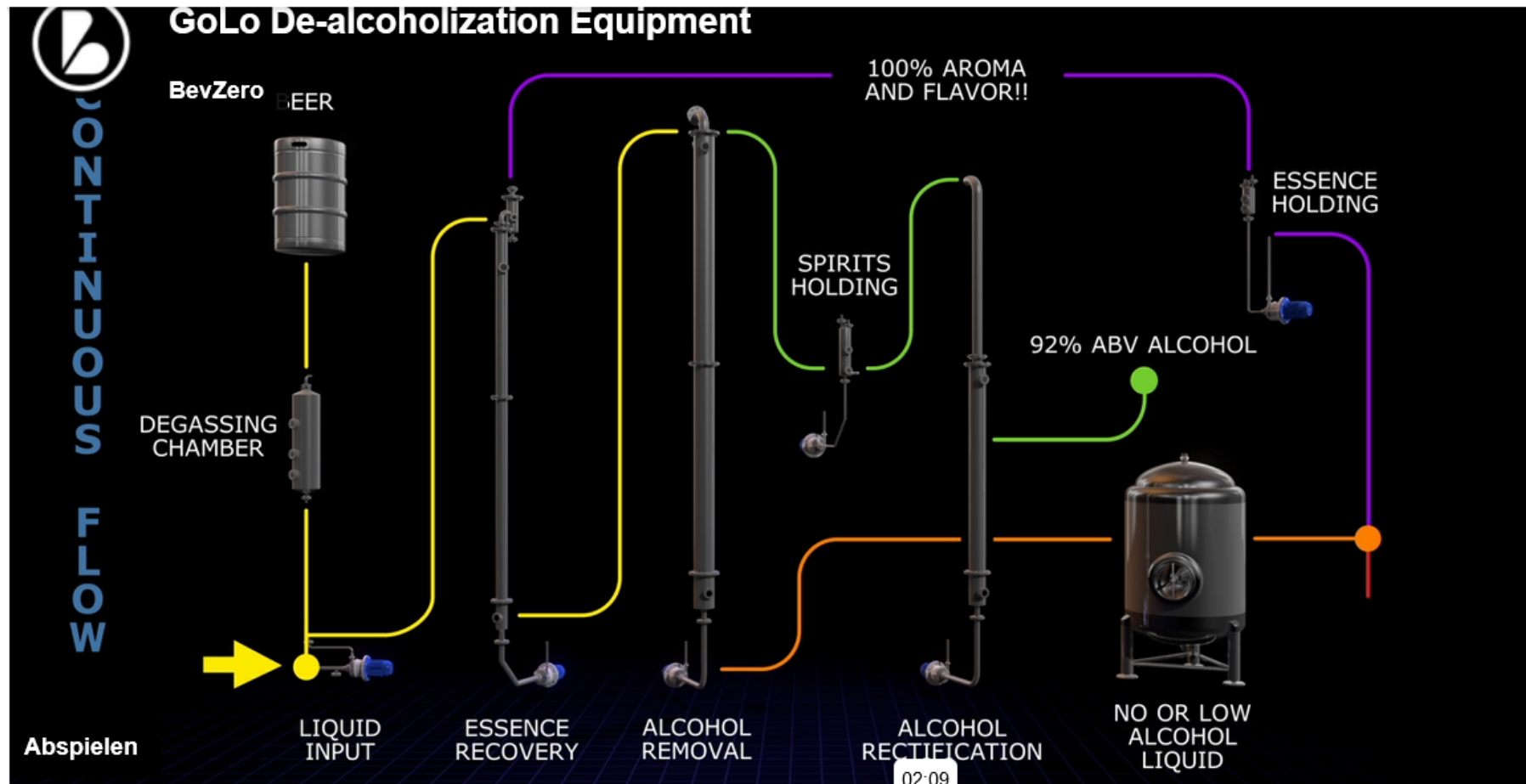

SPINNING CONE COLUMN / SCC

EXAMPLE FOR THE TREATMENT IN TERMS OF PARTIAL DE-ALCOHOLIZATION

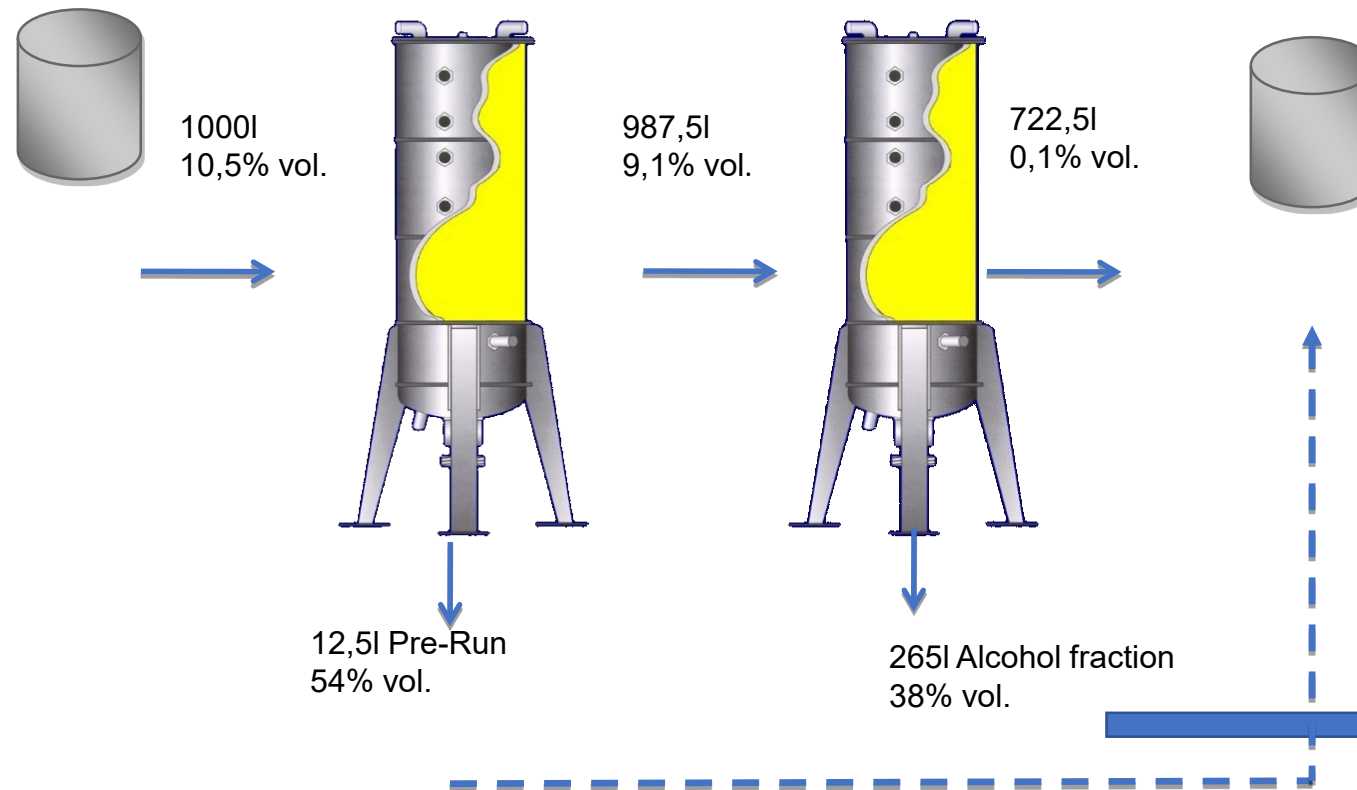

Example: ~ 25-35%
wine-liquid
(endogenous)
Can be partly recovered
by concentration
(further distillation)

AROMA RECOVERY DURING DEALCOHOLIZATION

A new commercial application for the recovery of aromas from spirits fractions based on adsorbers was investigated.

A distillate fraction from a dealcoholized Muscat wine (Gelber Muskateller/Muscat à petits grains blancs) was treated with an exchanger resin (Solos, Vaterstetten, Germany) to recover aromas from the dealcoholization process.

The recovered fraction was then added to the dealcoholized fraction to compensate for aroma losses during distillation under vacuum.

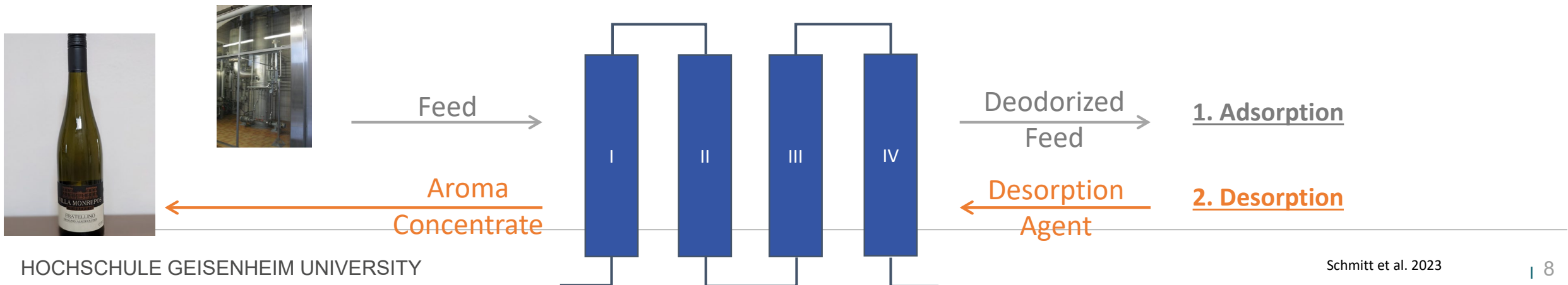

SENSORY EFFECT OF ETHANOL

Ethanol is the major volatile component in wine

The sensory effect of ethanol in wine is complex and far-ranging

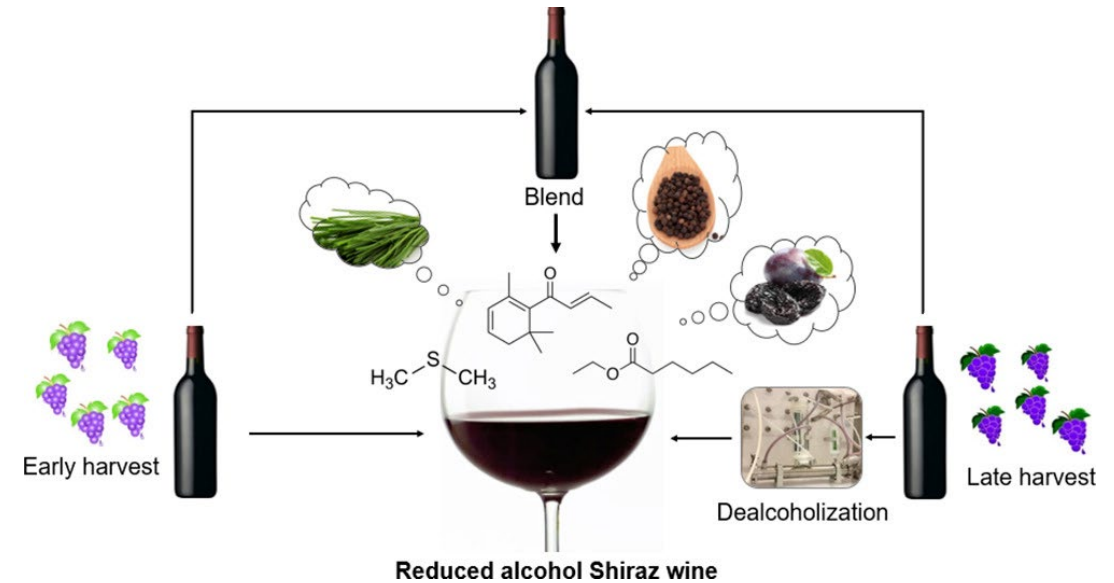

↑ Alcohol enhances	↓ Alcohol reduces
„Heat“ – thermal effect	Fruitiness
Body	Aroma intensity
Sweetness	Acidity
Bitterness	saltiness

Major changes on sensory profile due to removal of alcohol!

→ **Enological interventions** to buffer/re-balance those changes necessary!

Compound	Partition coefficient
Nitrogen ¹	62.0
Oxygen ¹	32.2
Carbon Dioxide ⁴	1.46
Ethylhexanoate ³	0.00885
Isoamylacetate ³	0.00821
Ethylacetate ³	0.00373
Ethanol ⁴	0.00026
Isoamylalcohol ³	0.00017

SENSORY EFFECT OF ETHANOL REMOVAL

The de-alcoholisation of ethanol from wine can cause some „collateral damage“ such as:

- Thermal damage
- Severe oxidation
- Microbiological spoilage
- CO2 loss
- Severe aroma losses

The 12-20% volume loss goes along with concentration effect of non-volatile components

Produktrückruf

Alkoholfreie Weiß- und Rotweine wegen Explosionsgefahr zurückgerufen

Tellen 



Produktrückruf: Diese Weinflaschen können wegen Nachgärung explodieren.

Product recall: De-alcoholized white and red wines recalled due to risk of explosion

Several studies show a significant reduction of mouthfeel in terms of body and fullness as major change

(Sam et al., 2021 Ma et al., 2022 Sam et al., 2021 Schmitt et al., 2023)

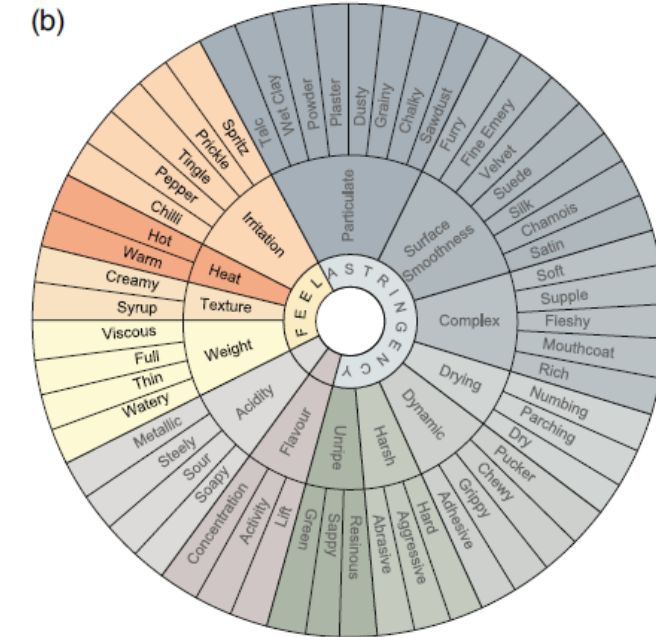
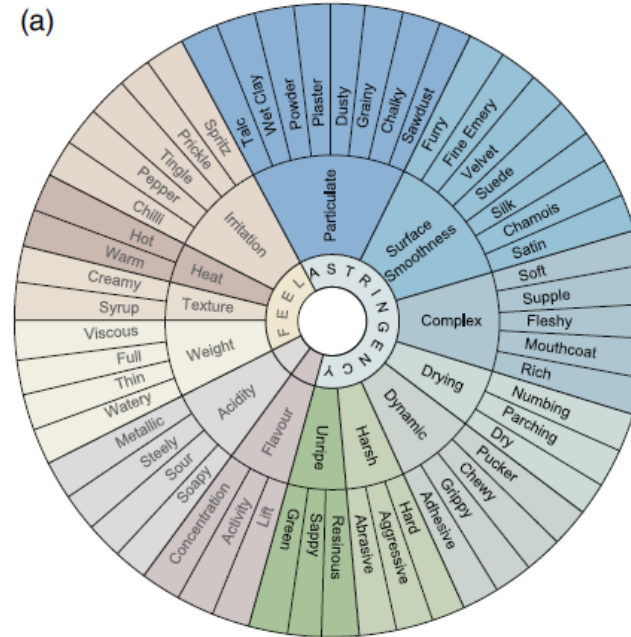
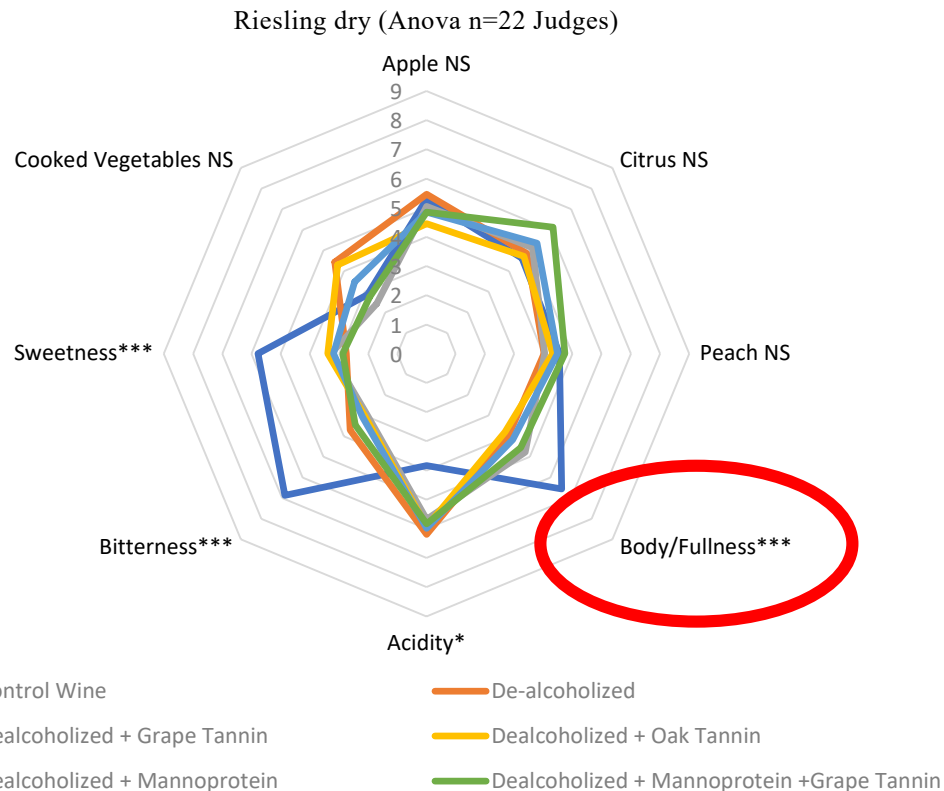

How to substitute ethanol?

Are all wine styles suitable for dealcoholization?
Red vs. Sparkling Wine?

SELECTION OF BASE WINES

When selecting the base wines, the following must be taken into account

- No sensory defects
- No residual sugar if possible
- Complex wine flavours
 - (wood, mature notes, spontaneous notes, etc.)
- Acidity of one to two grams per litre
 - per litre below the usual level
- No chaptalized wines!
 - Irrelevant for subsequent dealcoholisation! An obstacle for the industry. Many wines are not produced specifically for subsequent dealcoholisation.

There are several enological strategies to enhance / balance the body/mouthfeel of dealcoholized wine such as:

- Residual sugar
- Yeast mannoproteins
- Polysaccharides
- Tannins
- CO₂
- And others like Glycerol are in discussion
- **What about new thresholds for existing methods?**

→ Average sugar level on the market
~ 40g/L (Schmitt et al. 2023 and Podworny 2024)

Ranking according to preference

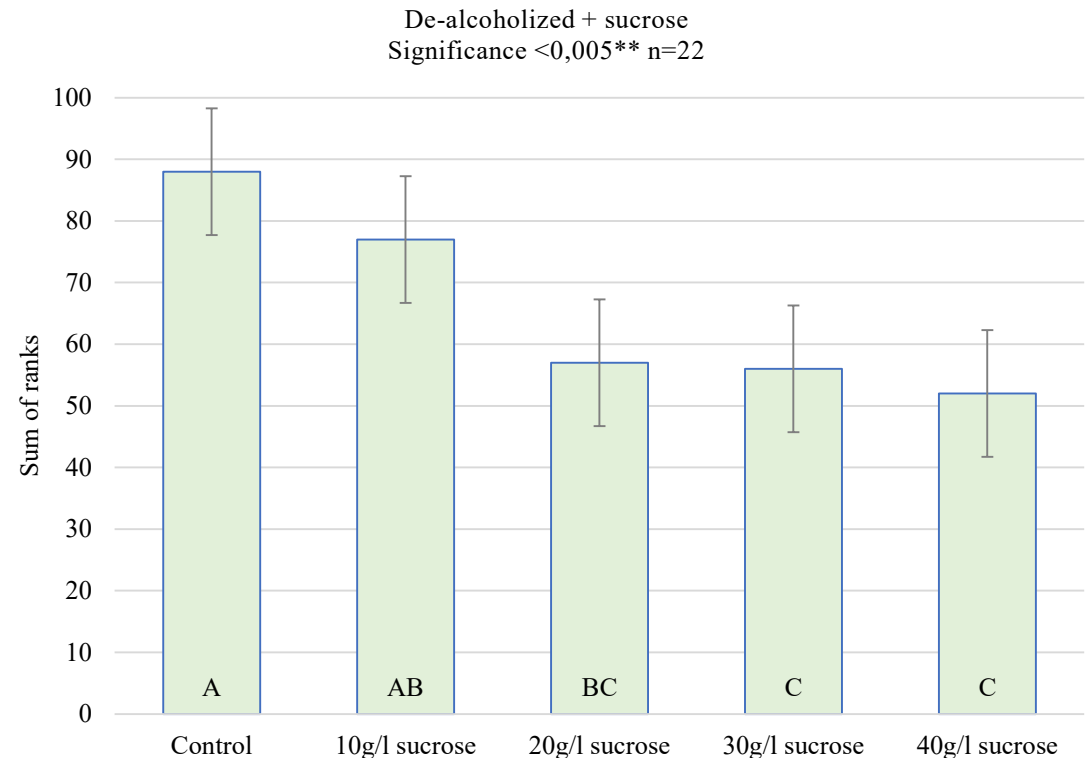

ENOLOGICAL INTERVENTION

Ranking according to personal preference

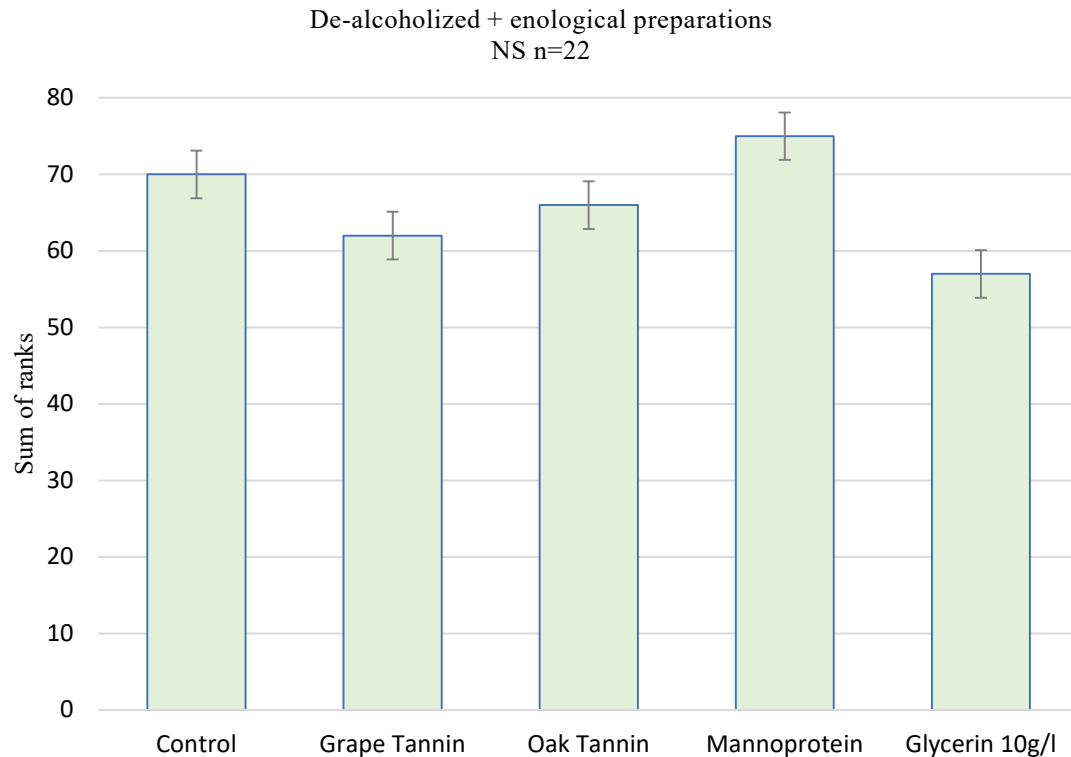

→ No effect through additions, even with Glycerol!

Ranking according to personal preference

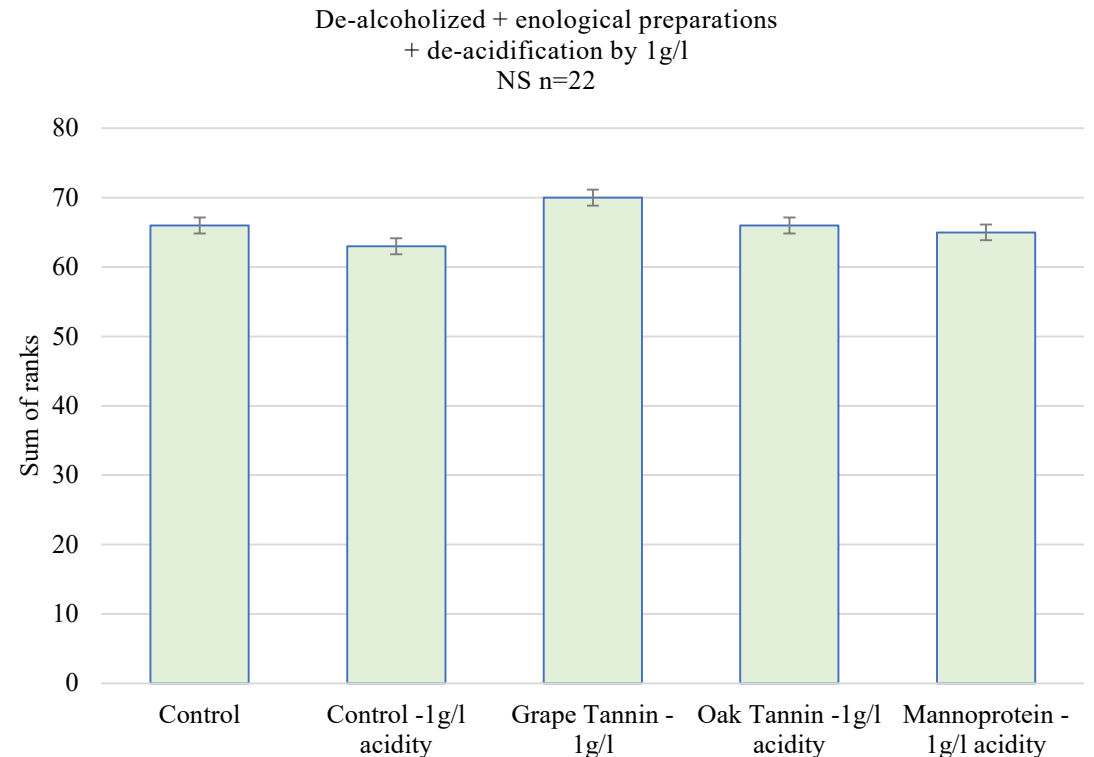

→ No effect through additions

SENSORY EFFEKT OF CO2

Tasting with Airen

CO2 acts as a trigeminal stimulant ranging from:

- tingling or prickling to mild irritation

Sensory threshold in wine is supposed to be 0,6g/l-0,8g/l

Slight increase in taste intensity scores is observed with carbonation for most flavors.

Carbonation can create new taste characteristics, primarily sour and/or bitter notes.

→ Therefore, it seems to be a promising solution to tailor dealcoholized wines to consumer

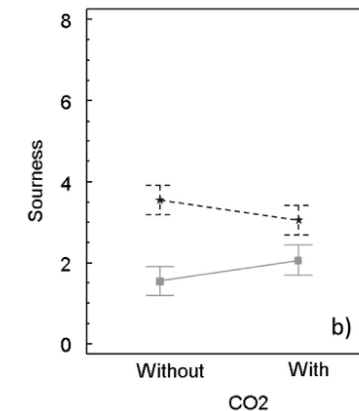
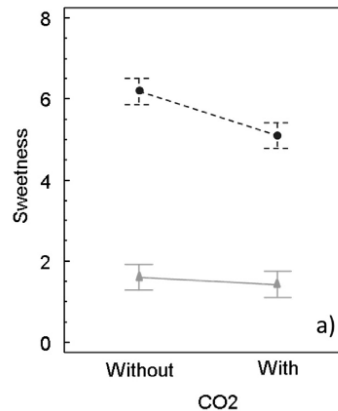

SENSORY EFFEKT OF CO₂

Carbon dioxide in beverages elicits sensations such as: "tingling," "prickling," "burning," "effervescence," and "sparkle."

It is widely recognized that insufficient CO₂ concentrations can lead to a wine tasting "flat" and lacking in freshness

Additionally, effervescence and fizziness is considered as the main sensory attributes of soft drinks, which play a crucial role in enhancing flavor and providing a refreshing sensation.

Majority of the German market for dealcoholized wine is above 3g/l (80% of the market!)

→ Threshold in dealcoholized wine "so far" unclear



SENSORY EFFECT OF CO₂

Tasting with Airen

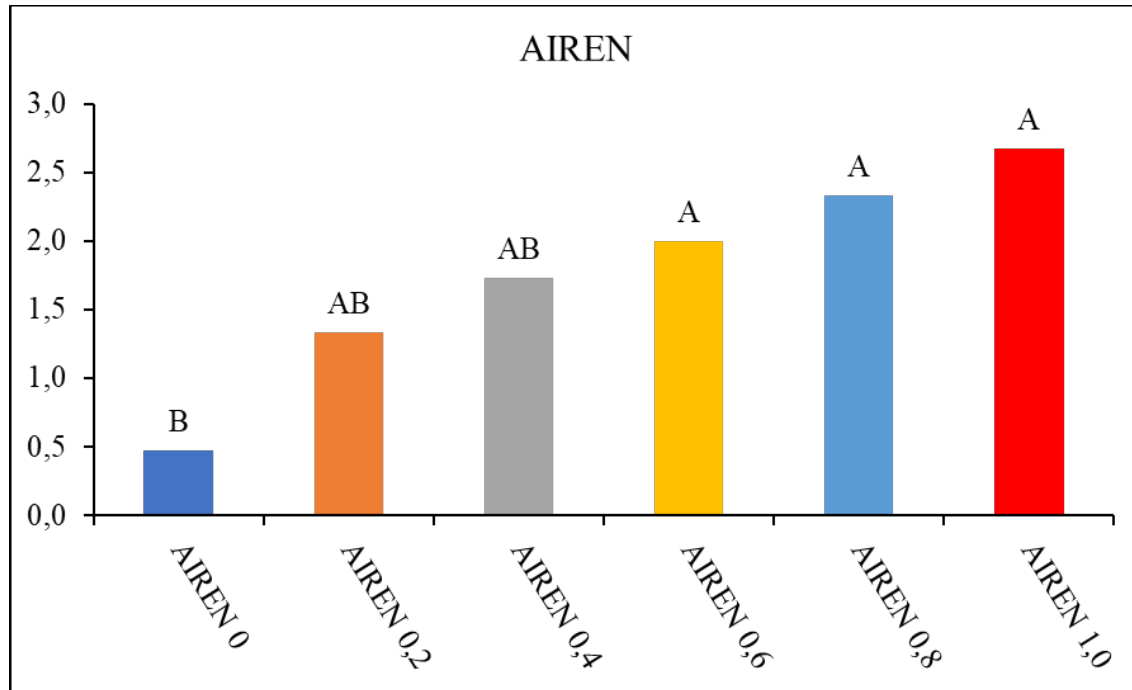

Threshold of CO₂

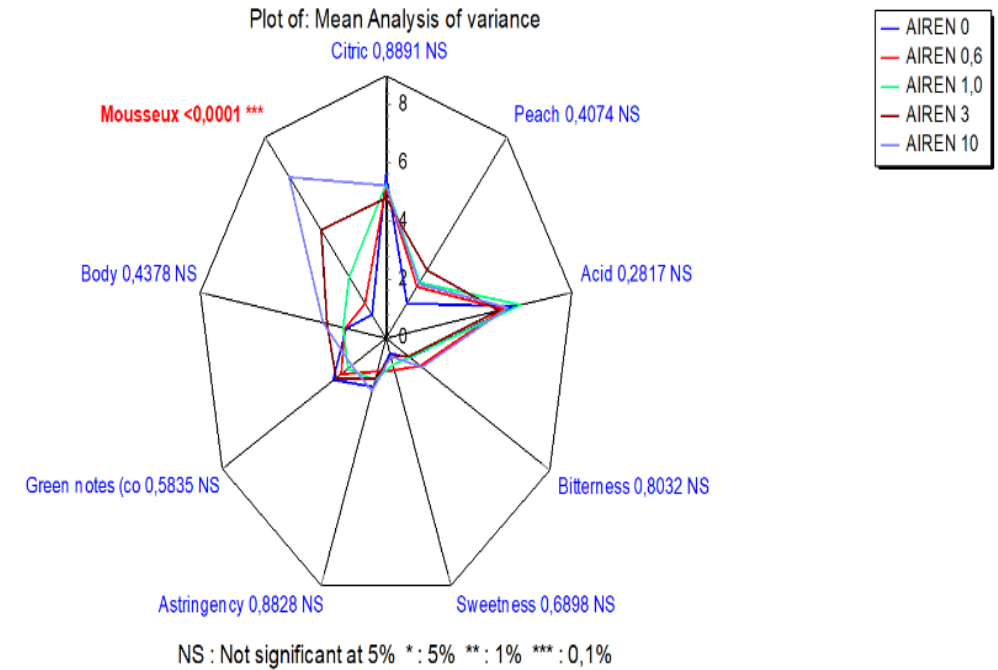

n=2x17

SENSORY EFFECT OF CO2

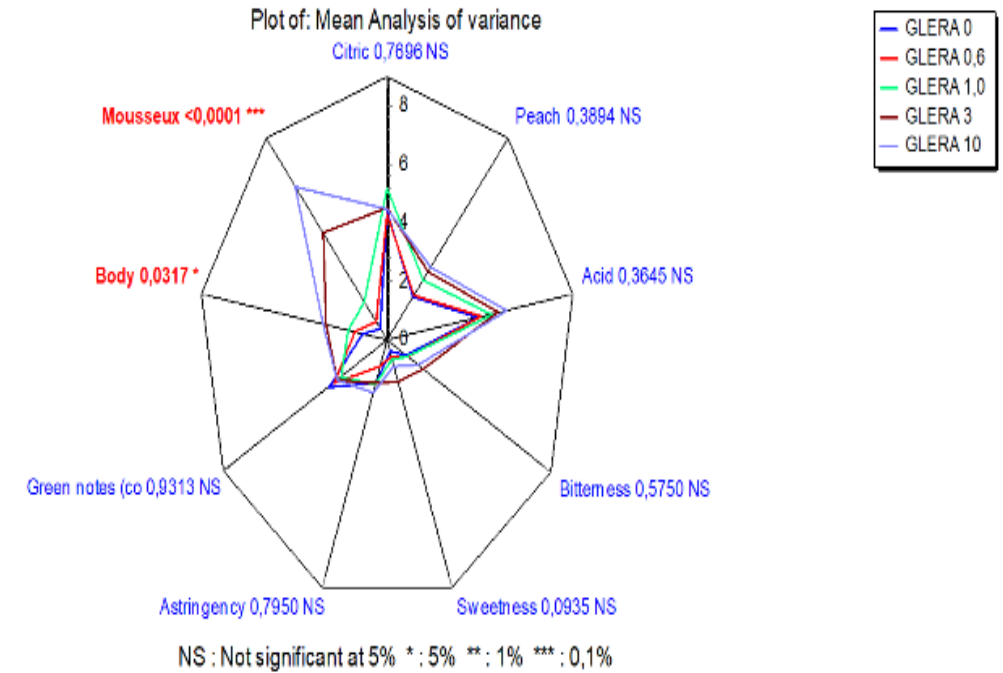
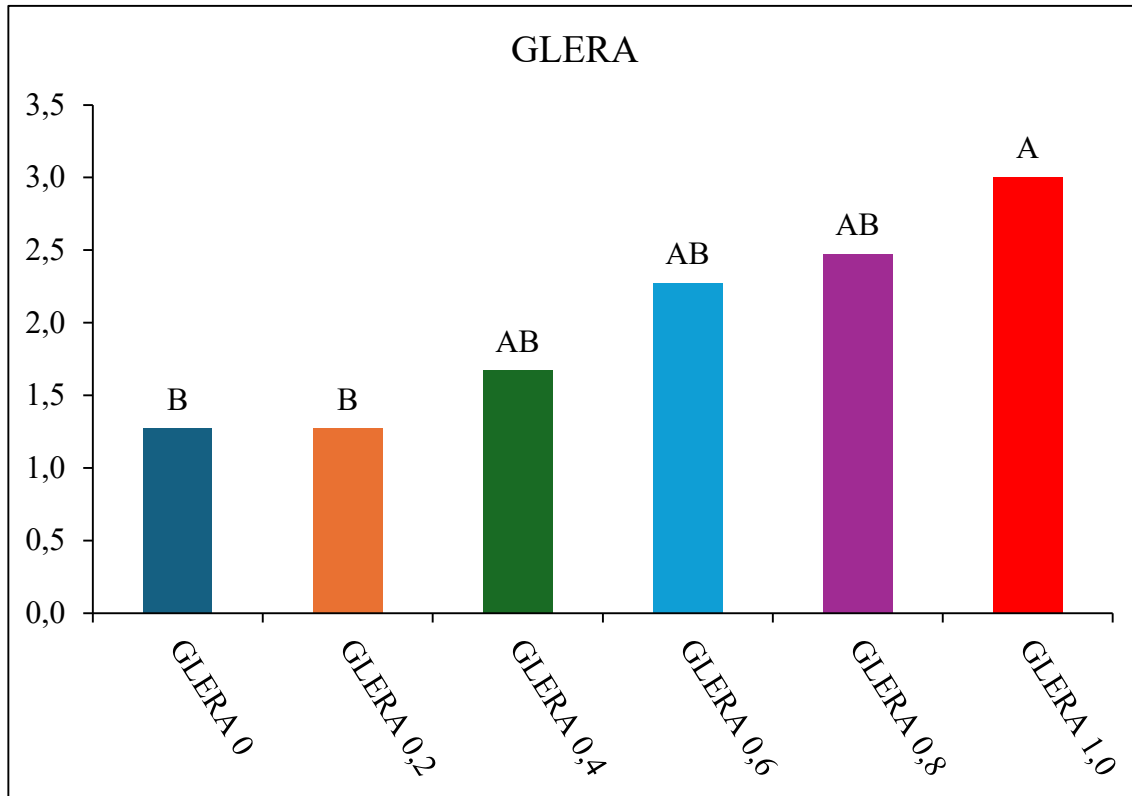

Elevated values of CO₂ increase body sensation in dealcoholized samples

n=2x17

SENSORY EFFECT OF GLYCEROL

Glycerol is the major polyol produced by fermentation

Glycerol ranges from **5 g/L** to **14 g/L** in dry and semi-dry wines and up to **25 g/L** in botrytised wines

In average red wines contain higher concentrations (**10,49g/L**) than white wines (**6,82g/L**)

The sensory impact of glycerol is not entirely clear.

It effects perceivable viscosity and body (dependend on the wine and glycerol concentrations)

The sensory threshold is about 5.2 g/L for sweetness, glycerol can be expected to contribute this attribute in dry wines, although this effect is probably not consistent with residual sugar

It does not contribute to the aroma of the wine due to its non-volatile characteristics, but it enhances smoothness and can bring some body to wine

Increased intake of glycerol (10g) can lead to digestive problems (Bundesinstitut für Arzneimittel und Medizinprodukte 2016)

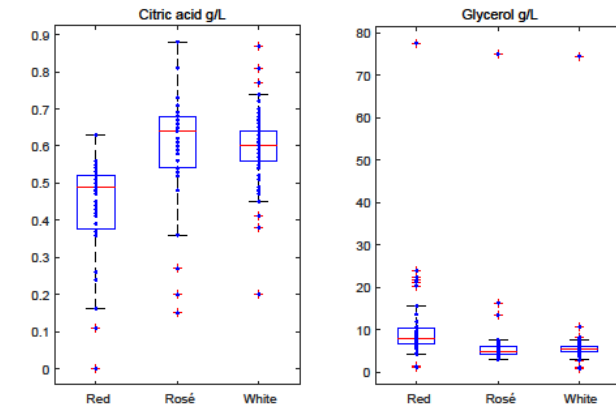
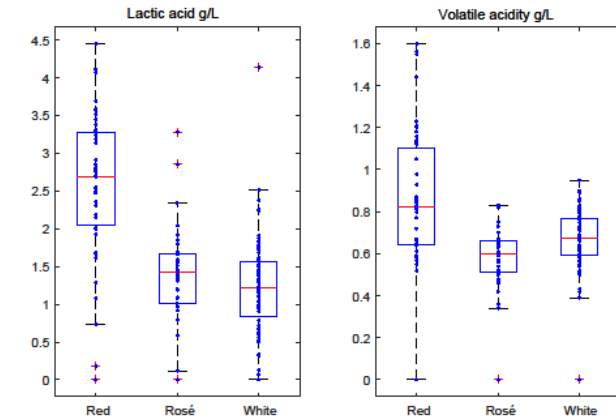

SENSORY EFFECT OF GLYCEROL

Study from 2023 on dealcoholized wines shows some odd values that indicate an addition.

Values where far above „wine-like“ values (>70g/l)

Indication that lower doses did not have a clear effect on the product quality???

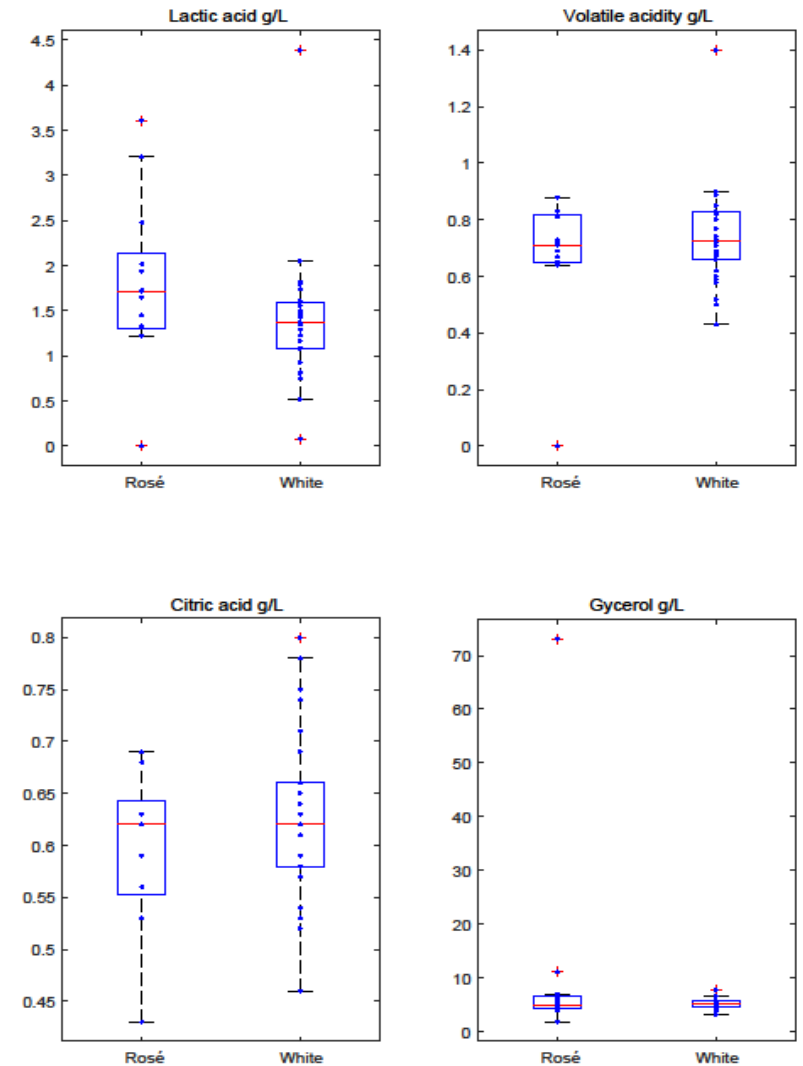

REALLY ALCOHOL-FREE????

0,0%? Necessary/ Zero etc...???

Opinions on this differ (see. DDW 22/2022)

Thesis (A. Niebrzydowska 2023) clear difference between D/PL

Dealcoholisation below 0.05% is very intensive and goes hand in hand with comparatively greater flavour losses

→ Marketing vs. Product quality?!

But it is essential for the designation as 'halal'

(Market significance unclear ~1%?)

From 0,5 to 0,05% vol. is as long as from 5 to 0,5% vol.

Rechtsmedizin 2012 · 22:244–247
DOI 10.1007/s00194-012-0835-8
Online publiziert: 29. Juni 2012
© Springer-Verlag 2012

A. Thierauf · M. Große Perdekamp · V. Auwärter
Institut für Rechtsmedizin, Universität Freiburg

Maximale Blutalkoholkonzentration nach forciertem Konsum von alkoholfreiem Bier



Tab. 1 Ergebnisse der Äthanolbestimmungen mit Angabe des Alters, des Geschlechts und des Körpergewichts des jeweiligen Probanden

Probanden-Nr.	1. positive Probe	SAK* (g/l)	2. positive Probe	SAK* (g/l)	Alter (Jahre)	Geschlecht	Körpergewicht (kgKG)
P01	Probe 1	Spur <0,001	–	–	42	Männlich	69
P03	Probe 1	0,0014	–	–	56	Weiblich	58
P11	Probe 2	0,0017	–	–	21	Weiblich	71
P16	Probe 2	Spur <0,001	–	–	47	Männlich	85
P18	Probe 2	0,0036	Probe 3	0,0012	21	Weiblich	51
P19	Probe 2	0,0037	Probe 3	0,0013	21	Weiblich	52
P21	Probe 2	Spur <0,001	–	–	20	Männlich	64
P22	Probe 1	Spur <0,001	–	–	19	Männlich	70
P30	Probe 2	Spur <0,001	–	–	30	Weiblich	70
P32	Probe 2	0,0015	–	–	29	Weiblich	64
P39	Probe 2	Spur <0,001	–	–	23	Weiblich	48
P55	Probe 1	0,0026	–	–	20	Männlich	71
P58	Probe 2	Spur <0,001	–	–	25	Weiblich	85
P62	Probe 1	0,0011	Probe 2	0,0069	75	Männlich	72
P64	Probe 1	0,0019	Probe 2	Spur <0,001	68	Männlich	80
P66	Probe 2	0,0013	–	–	22	Männlich	67
P70	Probe 1	0,0040	Probe 2	Spur <0,001	47	Weiblich	59
P72	Probe 2	0,0043	Probe 3	0,0018	70	Weiblich	57
P75	Probe 1	0,0038	Probe 2	Spur <0,001	19	Weiblich	55
P78	Probe 1	0,0013	–	–	20	Weiblich	65

Es sind die 20 von insgesamt 67 Probanden aufgeführt, bei denen in mindestens einer Probe Äthanol nachgewiesen werden konnte (Nachweisgrenze 0,0005 g/l) *Serumalkoholkonzentration (Mittelwert aus 4 Einzelbestimmungen).

'...Already 90 min after the start of drinking (corresponding to 30 min after the end of drinking) no more alcohol could be detected in any case. The highest serum alcohol concentration measured was 0.0069 g/l, corresponding to a BAC of 0.0056‰ (Pro-band 62...').

REALLY ALCOHOL-FREE????

Braucht es wirklich 0,0%? / Zero etc...???

 Amtsblatt der Europäischen Union DE Reihe L

2026/471

26.2.2026

VERORDNUNG (EU) 2026/471 DES EUROPÄISCHEN PARLAMENTS UND DES RATES

vom 24. Februar 2026

zur Änderung der Verordnungen (EU) Nr. 1308/2013, (EU) Nr. 251/2014 und (EU) 2021/2115 in Bezug auf bestimmte Marktvorschriften und sektorbezogene Unterstützungsmaßnahmen im Weinsektor und für aromatisierte Weinerzeugnisse und der Verordnung (EU) 2024/1143 über bestimmte Vorschriften für die Kennzeichnung von Spirituosen

DAS EUROPÄISCHE PARLAMENT UND DER RAT DER EUROPÄISCHEN UNION —

gestützt auf den Vertrag über die Arbeitsweise der Europäischen Union, insbesondere auf Artikel 42 Absatz 1, Artikel 43 Absatz 2 und Artikel 118 Absatz 1,

(22) De voorschriften voor de etikettering van wijnproducten moeten daarom worden gewijzigd zodat de consument beter wordt geïnformeerd over de kenmerken van wijnbouwproducten met een verlaagd alcoholgehalte, terwijl de verplichting om informatie te verstrekken over het gebruik van dealcoholisatie wordt behouden. Consumenten zijn vertrouwd met aanduidingen als "0,0 %" en "alcoholvrij". Dergelijke aanduidingen zijn echter in verschillende lidstaten op uiteenlopende wijze gereguleerd. De aanduidingen die verwijzen naar een verlaagd alcoholgehalte zouden moeten voldoen aan de Unievoorschriften voor het etiketteren van het verlaagde gehalte aan bepaalde stoffen. Daarom moet het gebruik van die aanduidingen in de hele Unie worden geharmoniseerd, zodat de wijnsector kan inspelen op nieuwe consumentenbehoeften terwijl de werking van de interne markt wordt gewaarborgd.

"a) de aanduiding voor de categorie van het wijnbouwproduct overeenkomstig bijlage VII, deel II. Voor de categorieën wijnbouwproducten die zijn gedefinieerd in bijlage VII, deel II, punt 1, en de punten 4 tot en met 9, wanneer een dealcoholisatiebehandeling overeenkomstig bijlage VIII, deel I, afdeling E, is toegepast op het geheel of een gedeelte van het product, wordt aangevuld met:

i) de aanduiding "alcoholvrij" indien het effectief alcoholvolumegehalte van het product ten hoogste 0,5 % bedraagt, met daarbij de vermelding "0,0 %", indien het effectief alcoholvolumegehalte van het product ten hoogste 0,05 % bedraagt;

ii) de aanduiding "verlaagd in alcohol" indien het effectief alcoholvolumegehalte van het product meer dan 0,5 % bedraagt en ten minste 30 % minder bedraagt dan het effectief alcoholvolumegehalte van de producten in de categorie vóór dealcoholisatie."

Rechtsmedizin 2012 · 22:244–247
 DOI 10.1007/s00194-012-0835-8
 Online publiziert: 29. Juni 2012
 © Springer-Verlag 2012

A. Thierauf · M. Große Perdekamp · V. Auwärter
 Institut für Rechtsmedizin, Universität Freiburg

Maximale Blutalkoholkonzentration nach forciertem Konsum von alkoholfreiem Bier



Tab. 1 Ergebnisse der Äthanolbestimmungen mit Angabe des Alters, des Geschlechts und des Körpergewichts des jeweiligen Probanden

Probanden-Nr.	1. positive Probe	SAK* (g/l)	2. positive Probe	SAK* (g/l)	Alter (Jahre)	Geschlecht	Körpergewicht (kgKG)
P01	Probe 1	Spur <0,001	–	–	42	Männlich	69
P03	Probe 1	0,0014	–	–	56	Weiblich	58
P11	Probe 2	0,0017	–	–	21	Weiblich	71
P16	Probe 2	Spur <0,001	–	–	47	Männlich	85
P18	Probe 2	0,0036	Probe 3	0,0012	21	Weiblich	51
P19	Probe 2	0,0037	Probe 3	0,0013	21	Weiblich	52
P21	Probe 2	Spur <0,001	–	–	20	Männlich	64
P22	Probe 1	Spur <0,001	–	–	19	Männlich	70
P30	Probe 2	Spur <0,001	–	–	30	Weiblich	70
P32	Probe 2	0,0015	–	–	29	Weiblich	64
P39	Probe 2	Spur <0,001	–	–	23	Weiblich	48
P55	Probe 1	0,0026	–	–	20	Männlich	71
P58	Probe 2	Spur <0,001	–	–	25	Weiblich	85
P62	Probe 1	0,0011	Probe 2	0,0069	75	Männlich	72
P64	Probe 1	0,0019	Probe 2	Spur <0,001	68	Männlich	80
P66	Probe 2	0,0013	–	–	22	Männlich	67
P70	Probe 1	0,0040	Probe 2	Spur <0,001	47	Weiblich	59
P72	Probe 2	0,0043	Probe 3	0,0018	70	Weiblich	57
P75	Probe 1	0,0038	Probe 2	Spur <0,001	19	Weiblich	55
P78	Probe 1	0,0013	–	–	20	Weiblich	65

Es sind die 20 von insgesamt 67 Probanden aufgeführt, bei denen in mindestens einer Probe Äthanol nachgewiesen werden konnte (Nachweislänge 0,0005 g/l) *Serumalkoholkonzentration (Mittelwert aus 4 Einzelbestimmungen).

'...Already 90 min after the start of drinking (corresponding to 30 min after the end of drinking) no more alcohol could be detected in any case. The highest serum alcohol concentration measured was 0.0069 g/l, corresponding to a BAC of 0.0056‰ (Pro-band 62...').

There are several enological strategies to enhance / balance the body/mouthfeel of dealcoholized wine such as:

- Residual sugar (removal of alcohol corresponds to approximately **25g/L sugar!!!**)
- Yeast mannoproteins
- Polysaccharides
- Tannins
- CO₂
- And others like Glycerol are in discussion
- **What about new thresholds for existing methods?**

Home > Archives > Vol. 58 No. 4 (2024): OENO One > Short communications

SHORT COMMUNICATIONS

In a fully dealcoholised Chardonnay wine, sugar is a key driver of liking for young consumers

Olivier Geoffroy , Maeva Podworny, Laura Brian, Marianne Gosset, Magali Peter, Foued Cheriet
Vol. 58 No. 4 (2024): OENO One
Received : 4 September 2024; Accepted : 18 October 2024; Published : 5 November 2024
DOI: <https://doi.org/10.20870/oeno-one.2024.58.4.8290>

ARTICLE AUTHORS SUPPLEMENTARY DATA METRICS

Ranking according to preference

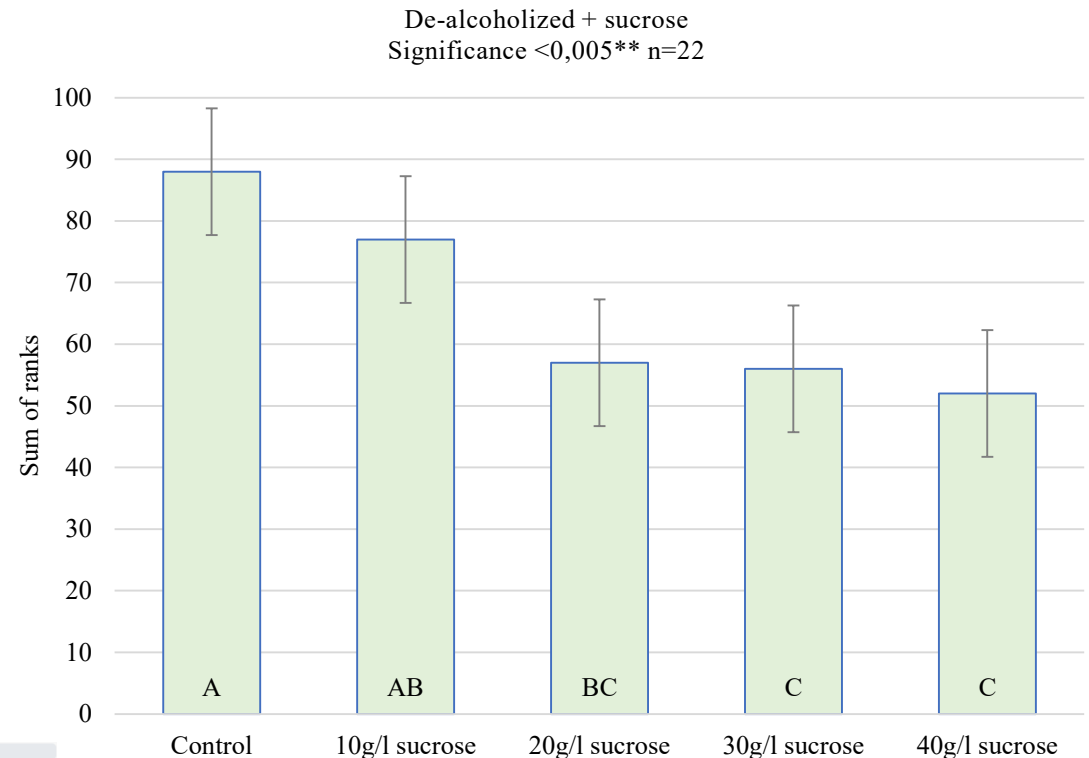

FURTHER PRODUCTS? ALTERNATIVES? PROXYS?



PROXYS?



Flight 1 3 wines each

Effect of CO₂ on the sensory matrix

- A) Initial Wine
- B) 0g/L
- C) 1,6g/L
- D) 3g/L
- E) 10g/L

Flight 2

Residual Sugar? Edulcoration?

- What is the right amount and the right choice in terms of sugar?
- A) 30g/L residual sugar – unfermented must
- B) 30g/L residual sugar – rectified grape ,must

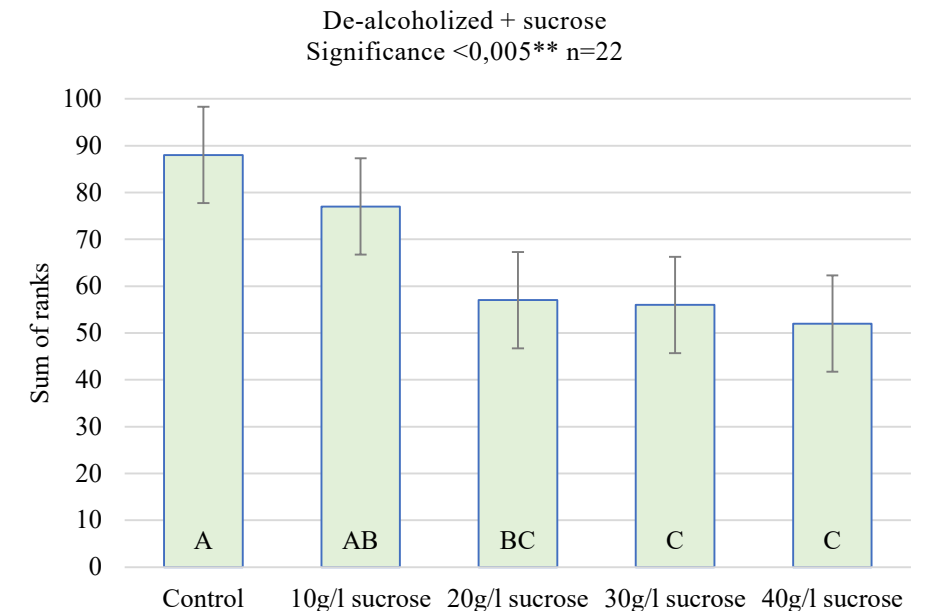

Flight 3

Dealcoholized Sparklings?

- A)

- B)

Contact:

Hochschule Geisenheim University

Matthias Schmitt

Von Lade Strasse 1

D 65366 Geisenheim

Matthias.Schmitt@hs-gm.de

